

Production & Industrial Engineering

Manufacturing Process - II



Comprehensive Theory
with Solved Examples and Practice Questions





MADE EASY Publications Pvt. Ltd.

Corporate Office: 44-A/4, Kalu Sarai (Near Hauz Khas Metro Station), New Delhi-110016 | **Ph. :** 9021300500

Email : infomep@madeeasy.in | **Web :** www.madeeasypublications.org

Manufacturing Process - II

Copyright © by MADE EASY Publications Pvt. Ltd.

All rights are reserved. No part of this publication may be reproduced, stored in or introduced into a retrieval system, or transmitted in any form or by any means (electronic, mechanical, photo-copying, recording or otherwise), without the prior written permission of the above mentioned publisher of this book.



MADE EASY Publications Pvt. Ltd. has taken due care in collecting the data and providing the solutions, before publishing this book. In spite of this, if any inaccuracy or printing error occurs then **MADE EASY Publications Pvt. Ltd.** owes no responsibility. We will be grateful if you could point out any such error. Your suggestions will be appreciated.

EDITIONS

First Edition : 2020
Second Edition : 2021
Third Edition : 2022
Fourth Edition : 2023
Fifth Edition : 2024
Sixth Edition : 2025

Seventh Edition : 2026

CONTENTS

Manufacturing Process-II

CHAPTER 1

Introduction to Machine Tools..... 1

1.1 Elements of Machine Tool.....	1
1.2 Functional Principle of Machine Tool Operation	4
1.3 Classification of Machine Tools	5
1.4 Generation and Forming	6
1.5 Accuracy and Finish Achievable	7
<i>Student's Assignments</i>	9

CHAPTER 2

Centre Lathe 10

2.1 Components of Centre Lathe	11
2.2 Lathe Specifications	12
2.3 Work Holding Device and Accessories	12
2.4 Operations Performed in Centre Lathe	14
2.5 Machining Time and Power Estimation for Turning	19
<i>Student's Assignments</i>	27

CHAPTER 3

Milling and Reciprocating Machines 29

3.1 Types of Milling Machine.....	29
3.2 Milling Cutters	31
3.3 Up and Down Milling	35
3.4 Milling Mechanics.....	36
3.5 Estimation of Cutting Speed, Number of Strokes and Net Shaping Time	44
<i>Student's Assignments</i>	48

CHAPTER 4

Abrasive Machines and Hole Making Processes..... 50

4.1 Major Advantages and Applications of Grinding.....	50
--	----

4.2 Interaction of the Grit with the Workpiece.....	51
4.3 Effect of Grinding Velocity and Grit Rake Angle on Grinding Force.....	51
4.4 Residual Stress.....	52
4.5 Designation and Selection of Grinding Wheel	52
4.6 Selection of Grinding Wheel	53
4.7 Grinding Wheel Wear.....	53
4.8 Specific Energy Consumption in Grinding.....	55
4.9 Grinding Ratio	55
4.10 Grinding Operation and Machines	56
4.11 Finishing Operations.....	58
4.12 Drilling.....	62
4.13 Reaming	66
4.14 Trepanning	67
4.15 Boring	67
4.16 Counter Sinking.....	68
4.17 Broaching Operation	69
<i>Student's Assignments</i>	71

CHAPTER 5

Metal Cutting..... 73

5.1 Terminology of Single Point Cutting Tool.....	73
5.2 Nose Radius	77
5.3 Tool Signature.....	77
5.4 Mechanism of Chip Formation	78
5.5 Orthogonal and Oblique Cutting	80
5.6 Types of Chips.....	82
5.7 Chip Breakers	83
5.8 Forces Developed in a Single Point Cutting Tool	84
5.9 Merchant's Analysis for Chip Formation.....	86
5.10 Assumptions of Merchant's Circle	88
5.11 Velocity Triangle for Orthogonal Cutting.....	88

5.12 Work Done and Specific Cutting Energy during Metal Cutting	89
5.13 Theories of Metal Cutting	90
5.14 Thermal Aspects of Metal Cutting	91
5.15 Machinability	94
5.16 Tool Wear and Tool Failure	95
5.17 Economics of Metal Cutting	101
5.18 Cutting Fluid	102
5.19 Cutting Tool Materials	103
5.20 Mechanics of Oblique Cutting	120
<i>Student's Assignments</i>	126

CHAPTER 6

<i>Non-Traditional Machines</i>	134
6.1 Electrical Discharge Machining (EDM)	135
6.2 Electrochemical Machining (ECM)	139
<i>Student's Assignments</i>	153

CHAPTER 7

<i>Advanced Machining Methods</i>	158
7.1 NC Machines	158
7.2 Types of Control Circuit	161
7.3 Computer Numerical Control (CNC) Machine Tools	162
7.4 Interpolation	163
7.5 Part Programming	164
7.6 Adaptive Numerical Control (ANC)	165
7.7 Direct Numerical Control (DNC)	165
7.8 Machining Centre	166
7.9 Introduction to CAD/CAM	167
7.10 Group Technology (GT)	169
7.11 Cellular Manufacturing	170
7.12 Flexible Manufacturing System (FMS)	171
7.13 Just-In-Time (JIT) Production	172
7.14 Industrial Robots	172
7.15 Additive Manufacturing	180
<i>Student's Assignments</i>	181



Introduction to Machine Tools

INTRODUCTION

Most of the engineering components such as gears, bearings, clutches, tools, screws and nuts etc. need dimensional and form accuracy and good surface finish for serving their purposes. Performing like casting, forging etc. generally cannot provide the desired accuracy and finish. For that such preformed parts, called blanks, need semi-finishing and finishing and it is done by machining and grinding. Grinding is also basically a machining process.

Machining to high accuracy and finish essentially enables a product:

- fulfill its functional requirements
- improve its performance
- prolong its service

A machine tool is a non-portable power operated and reasonably valued device or system of devices in which energy is expended to produce jobs of desired size, shape and surface finish by removing excess material from the preformed blanks in the form of chips with the help of cutting tools moved past the work surface(s).

1.1 Elements of Machine Tool

- (a) Work holding device- Chuck
- (b) Tool holding device- Tool post
- (c) Work motion mechanism- Head stock
- (d) Tool motion mechanism- Carriage, saddle
- (e) Support structure- Bed

1.1.1 Common parts and features

Bed :

Important conditions in design of bed are : Rigidity, alignment, accuracy, damping qualities

It is generally made of gray cast iron

Casting process is used to manufacture beds

X, I, H shaped. (Free space required)

V_{\max}, V_{\min} = Maximum, minimum cutting speed
 D_{\max}, D_{\min} = Maximum, minimum diameter of workpiece

NOTE : Rather than selecting the industrial cutting speeds between maximum and minimum speeds arbitrary, they are chosen according to G.P.

Thus intermediate speeds can be obtained

$$N_{\max} = N_{\min} (r)^{n-1} \qquad r = \left(\frac{N_{\max}}{N_{\min}} \right)^{\frac{1}{n-1}}$$

For e.g. 11 speeds is to be chosen between 100 and 4500 then

$$r = \left(\frac{4500}{100} \right)^{\frac{1}{11}} = 1.4$$

Example 1.1

A drilling machine is to be designed with 10 spindle speeds ranging between

150 to 1500 rpm. 7th spindle of the machine is ____ rpm.

Solution :

Since we know that speeds of machine tool is in G.P., let r be the common ratio of G.P.,

$$r = \left(\frac{1500}{150} \right)^{\frac{1}{10}} = 1.259$$

$$N_7 = 597.37 \text{ rpm}$$

1.1.3 Common Parameters of Machining

1. Speed (N)

$$\text{Maximum spindle speed, } N_{\max} = \frac{1000V_{\max}}{\pi D_{\min}}$$

$$\text{Minimum spindle speed, } N_{\min} = \frac{1000V_{\min}}{\pi D_{\max}}$$

where, V_{\max} = Maximum cutting speed to be used (m/min)

V_{\min} = Minimum cutting speed to be used (m/min)

D_{\max} = Maximum diameter of the workpiece/cutter (mm)

D_{\min} = Minimum diameter of the workpiece/cutter (mm)

The speed range (N_r) is defined as the ratio of maximum to minimum spindle speeds to be used.

Typical range of values of N_r for various tools is given in the following table.

Machine tool	Speed range (N_r)
Center Lathe	40 to 60
Milling Machine	30 to 50
Drilling Machine	20 to 30
Grinding Machine	1 to 10

2. Feed (f)

Linear distance travelled for one revolution of workpiece along the length of tool is called feed.

3. Feed velocity

The velocity by which the tool is travelling along the workpiece.

$$\text{Feed velocity} = fN \text{ mm/min}$$

4. Depth of cut

It is the depth by which tool has been penetrated into the workpiece.

1.2 Functional Principle of Machine Tool Operation

Machine Tools produce desired geometrical surfaces on solid bodies (preformed blanks) and for that they are basically comprised of;

- Devices for firmly holding the tool and work
- Drives for providing power and motions to the tool and work
- Kinematic system to transmit motion and power from the sources to the tool-work
- Automation and control systems
- Structural body to support and accommodate those systems with sufficient strength and rigidity.

For material removal by machining, the work and the tool need relative movements and those motions and required power are derived from the power source(s) and transmitted through the kinematic system(s) comprised of a number and type of mechanisms.

1.2.1 Concept of Generatrix and Directrix

Depending on the two relative motions, various types of surfaces can be produced. To understand this in more details, let us consider a point P , see fig. (a), where the material is being cut at any particular instant. Now the cutting motion and feed (provided after completion of each cutting stroke) both are rectilinear, the machined surface will be plane (fig. (b)).

The line generated by cutting motion is called generatrix and the line obtained from feed motion is called directrix (fig. (c)).

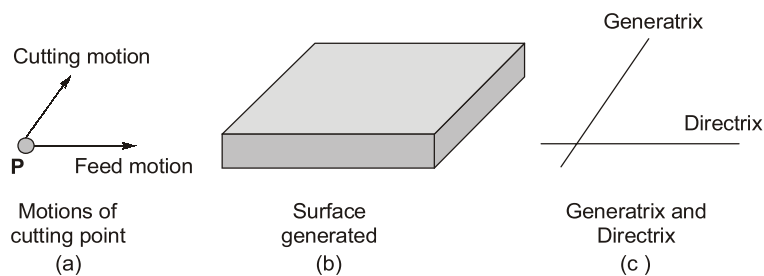

So, various shapes can be obtained depending on the shapes of generatrix and directrix and their relative motion.

Similarly, if the generatrix is a circle and directrix is a straight line perpendicular to the plane of generatrix then the surface obtained is cylindrical in nature. (see below fig.)



But on the other hand, if same circular generatrix and rectilinear directrix are in the same plane then two straight lines are generated as shown below in figure.

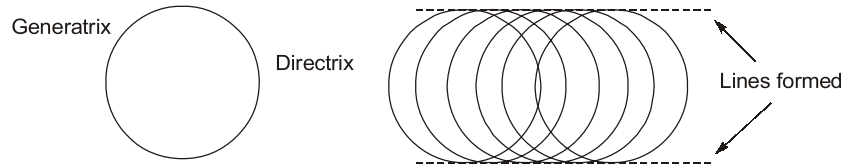

Table below gives the common example of surface generation.

S.no.	Generatrix	Directrix	Process	Surface obtained
1.	Straight line	Straight line	Tracing	Plain
2.	Circular	Straight line	Tracing	Cylindrical
3.	Plain curve	Circular	Tracing	Surface of revolution
4.	Circular	Straight line	Generation	Straight line (Plain surface in practice.)

1.3 Classification of Machine Tools

Machine tools are generally classified on the basis of production capability and application as follows:

I. General purpose machine tools

- These are designed to perform a variety of machining operations on a wide range of components but are not suitable for large production due to large setting time.
- They have large idle time and poor machine utilization.
- They are also known as basic machine tools.
- The basic machine tools which are commonly used for general purposes are :
 - ♦ Lathes
 - ♦ Drilling machines
 - ♦ Shaping machines
 - ♦ Planning machines
 - ♦ Slotting machines
 - ♦ Milling machines
 - ♦ Boring machines
 - ♦ Hobbing machines
 - ♦ Gear shaping machines
 - ♦ Broaching machines
 - ♦ Grinding machines

Each one of the machine tools, mentioned above, can be further classified into several types depending upon size, shape, automation, etc.

II. Production machine tools

- A number of functions of these machine tools are automated such that the operator skill required to produce a component is reduced.
- They have reduced idle time and improved machine utilization.
- General purpose machine tools can be converted to production machine tools by utilization of jigs and fixtures.
- Example- Capstan and turret lathe, automats and multiple spindle drilling machine.
- Setting time for a given job is more.
- They are justified only for large volume production.

III. Special purpose machine tools (SPM)

- In these machine tools, setting time for the job and tool is completely eliminated and complete automation is achieved.

- Cycle time and hence cost of the components is reduced.
- These are used for mass manufacturing.
- Example-Cam shaft grinding machine, connecting rod twin-boring machine, piston turning lathe etc.

IV. Single purpose machine tools

- These are designed specifically for doing a single operation on a class of job or on a single job.
- They have highest degree of automation and are used for really highest rate of production.
- They have least flexibility and are most cost effective.

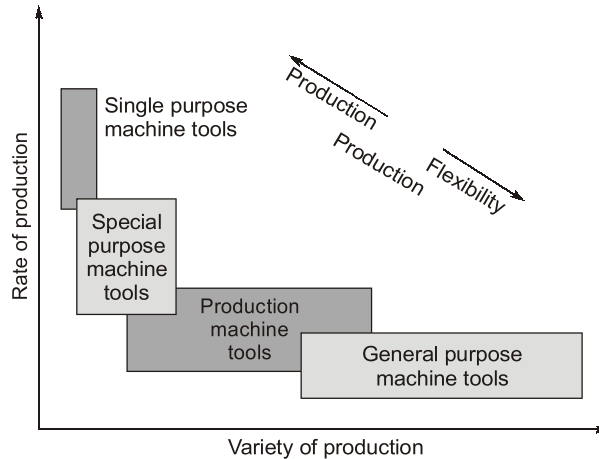

Fig. Application of machine tools based on the capability

1.4 Generation and Forming

For producing a certain shape of component in a machine tool, there are two different techniques namely generating and forming.

In generating, the required profile is obtained by manipulating the relative motion of workpiece and cutting edge of the tool. Hence in this technique, the obtained contour is different from the shape of cutting edge of tool. Example: cutting helical profile on a cylindrical workpiece with a single point cutting tool

The type of surface obtained by generating method depends on the primary motion of the workpiece and secondary motion(feed) of the tool.

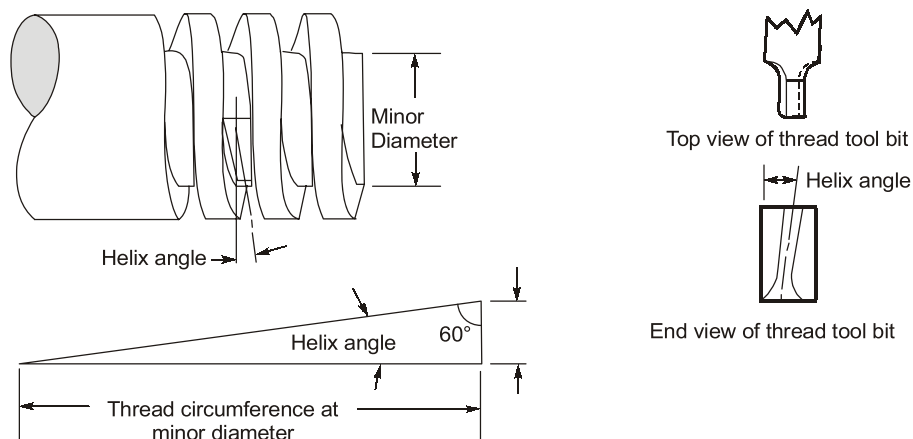

Fig. Helical profile generating

In forming technique, the shape of the cutting tool is impressed (forged) on the workpiece and the shape obtained is dependent on the shape of tool and also the accuracy of the shape obtained by forming depends on the accuracy of the form of tool used.

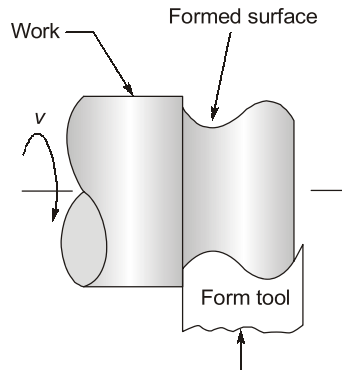

Fig. Surface forming

But most of the machine tool operations are combination of both generating and forming, for example cutting a dovetail profile on a plain surface is obtained by impressing and then sweeping an angular cutter in straight line as shown in figure below.

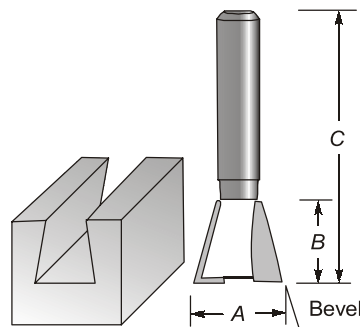

Fig. Dovetail forming

1.5 Accuracy and Finish Achievable

Any task required for manufacturing a component can be done in multiple machine tools through different processes and various operations and each one of them has its own characteristics in terms of accuracy, surface finish and cost. Hence the operation which optimizes accuracy, surface finish and total cost of the component is decided during process planning.

General values of accuracy and surface finish for rough cutting on various machine tools are given in tables below.

Table: Accuracy achievable in machining operations

Machining operation	Accuracy
Turning	+ 25 μm
Shaping, Slotting	+ 25 $\mu\text{m}/\text{side}$
Planing	+ 65 μm
Milling	+ 12 to 25 μm
Drilling in drill press location	+ 250 μm
Hole	+ 125 μm
Jig hole	+ 50 μm
Drilling in lathe–Location	+ 12 μm
Hole	+ 2.5 μm
Boring	+ 2.5 μm
Internal grinding	+ 2.5 μm
Reaming	+ 25 μm
Reaming with jig	+ 12.5 μm
Jig boring–Hole	+ 2.5 μm
Location	+ 5 μm
Cylindrical and surface grinding	+ 2.5 μm
Thread-cutting products	+ 50 μm
Broaching	+ 12.5 μm
Lapping	+ 5 μm
Honing	+ 12.5 μm
Super finishing	+ 0.5 μm

Table: Accuracy achievable in machining operations

Operations	Roughness (R.M.S.) microns										
	25	12.5	6.25	3.2	1.6	0.8	0.4	0.20	0.10	0.05	0.025
Flame cutting, Sawing											
Hand grinding											
Filing, Disc grinding											
Turning, Shaping, Milling											
Boring											
Drilling											
Surface grinding											
Cylindrical grinding											
Honing, Lapping											
Polishing											
Super finishing											
Buffing											





**Student's
Assignments**

1

- Q.1** Which of the following shape is obtained when generatrix are circular and directrix are straight line?
(a) Straight line
(b) Surface of revolution
(c) Cylindrical
(d) Plain surface
- Q.2** Which among the following machine tools have minimum setting time for job and tool?
(a) General purpose machine tools
(b) Production machine tools
(c) Special purpose machine tools
(d) Single purpose machine tools
- Q.3** General purpose machine tools are used
(a) For high production rate
(b) For large production volume
(c) For automated production
(d) In normal workshops and repair shops
- Q.4** Spindle speeds of machine tools are generally in Geometric progression because
(a) Difference between two consecutive speeds is fixed
(b) Vibrations are reduced
(c) It allows more uniform dispersion of speed in the entire range
(d) Total speeds in a given range are maximized

- Q.5** Which of the following is most precise definition of machine tool?
(a) It converts one type of energy to other
(b) Holds the workpiece and provides rotary motion
(c) Holds the workpiece and cutting tool for metal removal
(d) Holds the cutting tool for metal removal
- Q.6** Which among the following process provides highest dimensional accuracy?
(a) Cylindrical turning (b) Jig boring
(c) Shaping (d) Milling
- Q.7** Which among the following process provides best surface finish?
(a) Hand grinding
(b) Cylindrical grinding
(c) Cylindrical turning
(d) Milling
- Q.8** Which of the following is a load carrying member, which provides support to a machine tool?
(a) Spindle (b) Guideways
(c) Slideways (d) Machine structure

A N S W E R S

- 1. (d) 2. (c) 3. (d) 4. (c) 5. (c)**
6. (b) 7. (b) 8. (c)

